

AIROBOT V3



As standard equipment, includes:

- integrated CO₂, VOC, air temperature and humidity sensors
- autonomous control – smart control of fans ensures high-quality interior climate
- room occupancy sensing (together with energy saving mode)
- humidity detection mode.

Specifications

Installation	wall-mounted, vertically
Airflow up to	V3: 309 m ³ /h or 86 l/s or 140 m ² ventilated area V3 ERV: 286 m ³ /h or 80 l/s or 140 m ² ventilated area
Heat exchanger	HRV: plate heat exchanger with heat recovery ERV: plate heat exchanger with humidity and heat recovery
Heat recovery efficiency	V3: 89%, V3 ERV: 84%
Filters	panel filters, ePM10 55% (M5) / outside air ePM1 55% (F7)
Power supply	1~230 VAC 50 Hz
Maximum power	1.9 kW (10 A)
Motors	2 × 83 W RadiCal EC
Preheater (frost protection)	integrated, nominal power 1.35 kW PTC, 0–100% control
Special power SPI (V3 / V3 ERV)	0.31/0.31 W/(m ³ /h) ^{219 m³/h / 50 Pa}
Special power SFP (V3 / V3 ERV)	1.12 / 1.12 W/(m ³ /s) ^{219 m³/h / 50 Pa}
Condensate connection (mm)	32 mm
Colours	white, black
Packaging	80 × 60 × 60 cm, weight 45 kg

Energy labels

Airobot V3

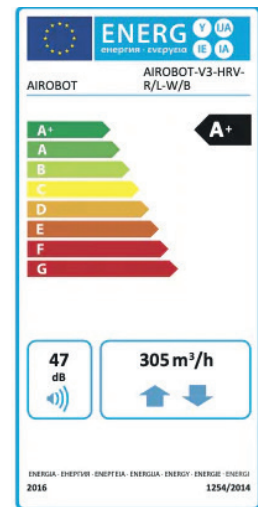

Airobot V3 ERV

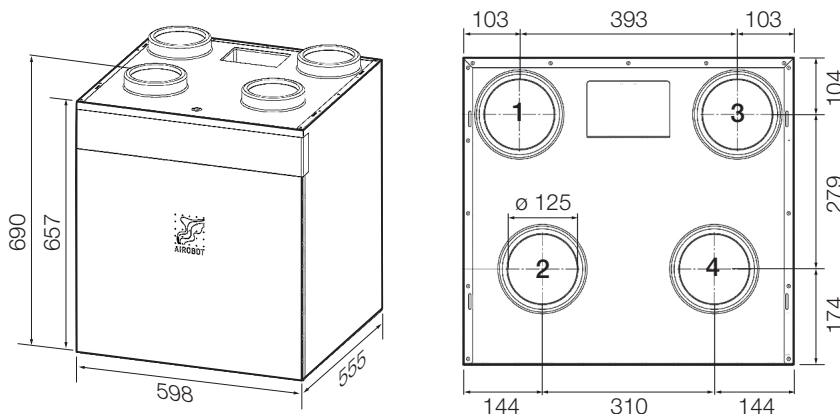
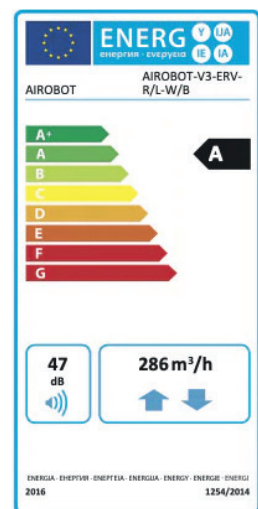

Ducts

Type R

1. Supply air
2. Extract air
3. Exhaust air
4. Outside air

Type L

1. Exhaust air
2. Outside air
3. Supply air
4. Extract air